



Larger body
Higher integration level



Greater mobility



Professional and fashionable
design on airframe and
remote control



Higher and
further flight



Panoramic shooting



Dual control
mode on camera



Rain and snow proof

AEE AP10 User Manual

V1.0 2014.07

Please carefully follow operating instructions in this "User Manual" to use the AP10 product.
Please refer to separated Disclaimer in the package.

Conventions

All of AP10's features described in this manual, unless particularly stated, are described while the product is in the operating mode.

Download AEE APP (iOS / Android)

Please download the AEE AP APP to simultaneously watch live video when using AP10, through the following method.



AEE AP



iOS 6.1 or above



While flying the quadcopter, if it suddenly starts to rain or snow, please land the quadcopter immediately and wipe it clean of any weather residue. Short periods of time in raining and snowing weather will not cause serious defects in the product.

Content

Conventions.....	1
Download AEE APP.....	1
Overview.....	3
1 Kit contents.....	3
2 Packing List.....	4
Preparations before use.....	5
1 Prepare the Battery.....	5
1.1 Quadcopter Battery Introduction.....	5
1.2 Charging the Quadcopter Battery.....	6
1.3 Installing Quadcopter Battery.....	6
1.4 Caution.....	7
2 Prepare the Quadcopter.....	7
2.1 Introduction.....	7
2.2 Flight Control System.....	7
2.3 Flight Indicator.....	8
2.4 Micro SD Card Slot.....	8
2.5 Onboard Camera.....	9
3 Prepare Propellers.....	9
3.1 Introduction.....	9
3.2 Installation Method.....	10
3.3 Removing Propellers.....	10
3.4 Precautions.....	10
4 Preparing the Transmitter.....	10
4.1 Introduction.....	11
4.2 Switching on the Transmitter.....	11
4.3 Antenna Signal Description.....	11
4.4 Transmitter Operating Instructions.....	12
4.5 Frequency Pairing between Transmitter and Receiver.....	13
5 Preparing the Repeater.....	13
5.1 Introduction.....	13
WiFi indicator.....	13
Power Indicator.....	13
Pairing Button.....	13
Code pairing.....	13
5.2 How to use.....	14
Charging the Repeater.....	14
Switching on the Repeater.....	14
Check Battery status.....	14
6 Downloading and Installing AEE AP APP.....	14
7 Connecting the Camera.....	15
Flying the Quadcopter.....	15
Flying Environment Requirements.....	15
Pre-flight Check.....	16
1 Compass Calibration.....	16
1.1 Calibration Procedures:.....	16
1.2 Situations when recalibration is required.....	16
2 Starting / Stopping the Motor.....	16
2.1 Starting the motor.....	16
2.2 Stopping the motor.....	17
3.Basic Flight.....	17
3.1 Basic Flight Procedures.....	17
3.2 Aerial Photography Tips and Tricks.....	17
4 Failsafe Protections.....	17
4.1 Scenarios when Quadcopter enters Failsafe mode.....	17
4.2 Failsafe and Return Procedure.....	17
4.3 How to regain control on the Transmitter.....	18
5 Battery Level Alarm Function.....	18
Using AEE AP APP.....	18
1 Download and Install AEE AP APP.....	18
2 Connect to AP10 System Network.....	18
3 Starting AEE AP APP.....	19
4 AEE AP APP Main Interface.....	19
5 Video Interface.....	20
6 Settings Interface.....	20
Appendix.....	22
1 Description of Common Indicators.....	22
2 Specifications.....	23
3 Common Troubleshooting.....	23
Limited Warranty.....	24





Overview

AP10 is a high-tech electronic product with integrated flight and Camera control. It is equipped with a 16 megapixel Camera and an advanced intelligent flight control system. You can use smart devices to remote control the Camera through the AEE AP APP, and achieve real-time transmission of video images. AP10 will help you effortlessly capture clear and stable aerial videos and photos.

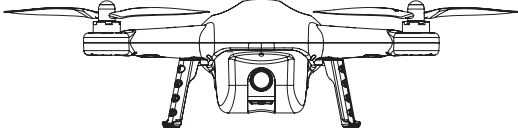
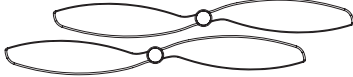
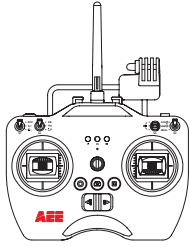
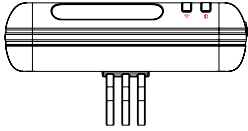
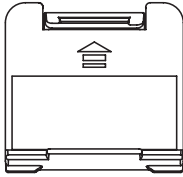
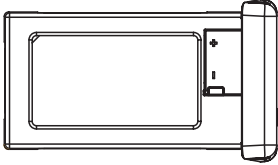
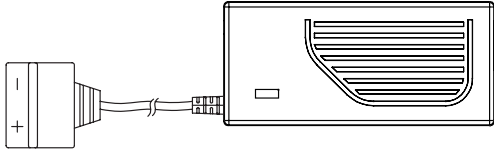
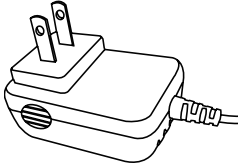
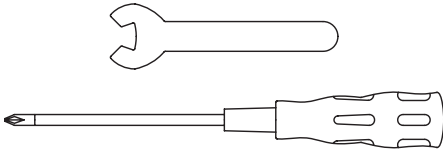
1 Kit contents

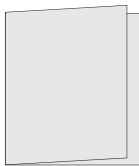
Before using, please packing List all items inside the kit box.

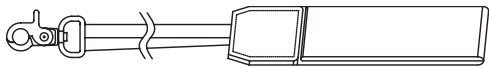
No.	Name	Diagram	Quantity	Description
1	Quadcopter		1 pcs	With inbuilt onboard Camera
2	Propellers		4 pairs	4 pcs propellers with black caps; 4pcs propellers with gray caps
3	Transmitter		1 pcs	Includes repeater mount
4	Repeater		1 pcs	Used to connect to smart devices using WiFi
5	Smart devices mount		1 pcs	Used to mount smart devices
6	Quadcopter Battery		1 pcs	Provides Power supply to the Quadcopter
7	Quadcopter Battery Charger		1 pcs	100-240V 50/60Hz
8	Repeater Adapter		1 pcs	100-240V 50/60Hz
9	Tools		1 set	1pcs wrench and 1pcs screwdriver for disassembling propellers

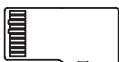
10	AA batteries		4 pcs	Used to supply Power for the transmitter
11	User Manual		1 pcs	Includes "AP10 User Manual"
12	Screws		1 pcs	For WIFI Repeater
13	Strap		1 pcs	Transmitter strap
14	CD		1 pcs	Possesses relevant AP10 information (optional)
15	Micro SD card		1 pcs	Installed within Micro SD card slot (optional)

• The accessories you have received may vary due to different customization, the package is subject to change without further notice.

2 Packing List

AP10 adopts a high standard integrated design, and is equipped with professional-grade airborne photography equipment and a repeater. It can provide excellent aerial photography for outdoor low-flying or large indoor spaces. After receiving this product, you need to conduct a simple installation process to fly your Quadcopter and take aerial pictures, and the Camera will automatically store images in the memory card. Users can control the Quadcopter in real time through the transmitter, and can view flight video through smart phone devices. This product is suitable for recreational or commercial photography applications, featuring simple and flexible operating procedures, with stable and reliable performance.

Transmitter Device	Quadcopter External Components	Quadcopter Operating Modes	Quadcopter Internal Components
Transmitter 2 pcs throttle Joysticks, multi-channel	Airborne Camera Power unit (motor & propellers)	GPS mode Normal mode Null (Reserve)	Flight Control System Wi-Fi module Receiver ESC (Electronic Speed Control)

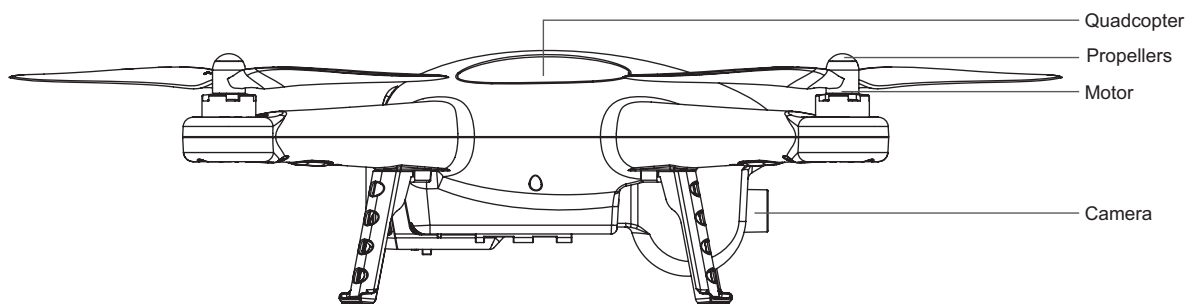

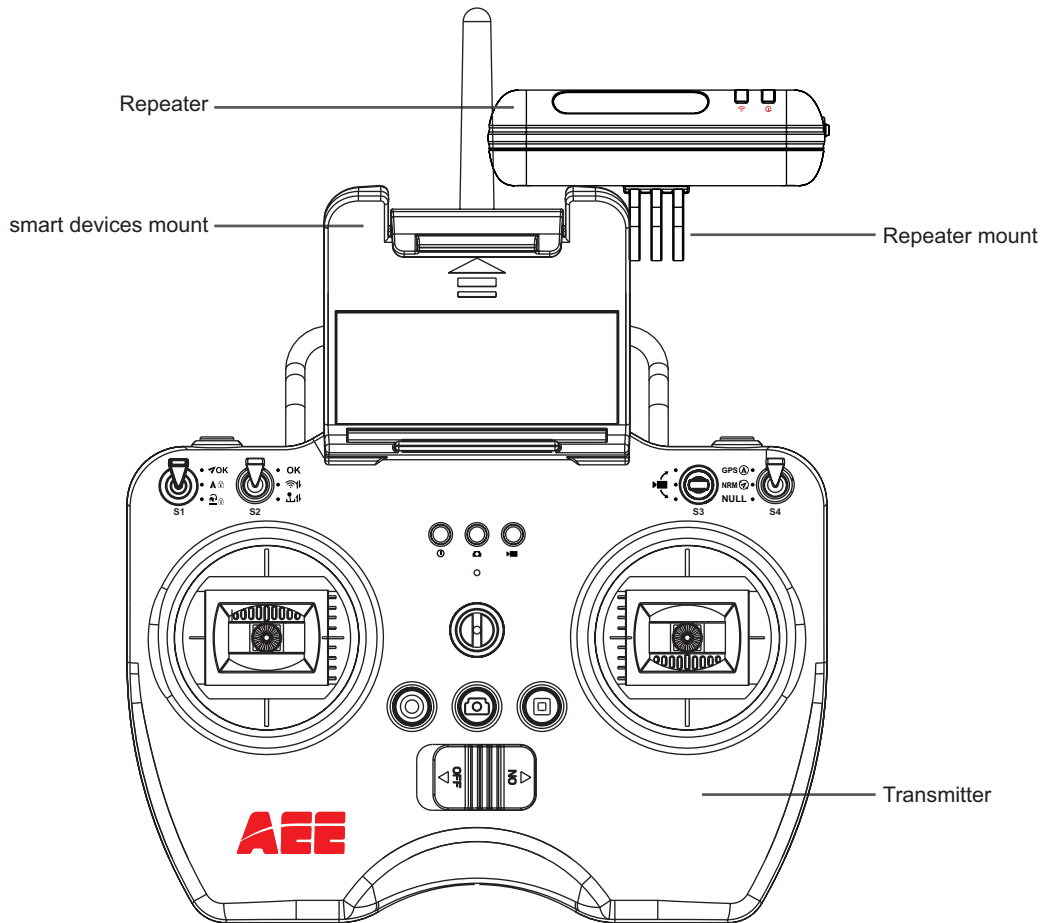

Preparations before use

Please refer to the following contents for component installation and preparations before flying the Quadcopter.

1 Prepare the Battery

Please make sure the following device batteries are fully charged before using AEE AP10.

Equipment	Power Supply
Transmitter	Install four AA batteries for Power supply.
Repeater	Repeater needs to be charged through the inbuilt charging port (mini USB port).
Quadcopter	Charged Quadcopter batteries for Power supply.
Smart devices	Please ensure that your smart devices is fully charged before using AEE AP APP

The following instructions are about - How to use the Quadcopter Battery.

1.1 Quadcopter Battery Introduction

The Quadcopter Battery (Figure 2) is a unique Battery with charge and discharge management functions. It is specifically designed for AP10 Standard. You must use the Quadcopter Battery charger (Figure 3) provided by AEE for charging.

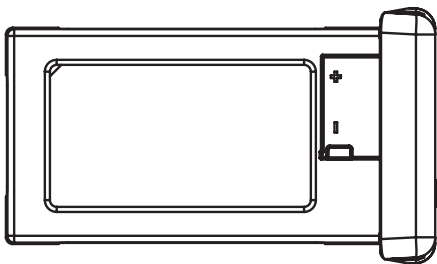

Figure 2

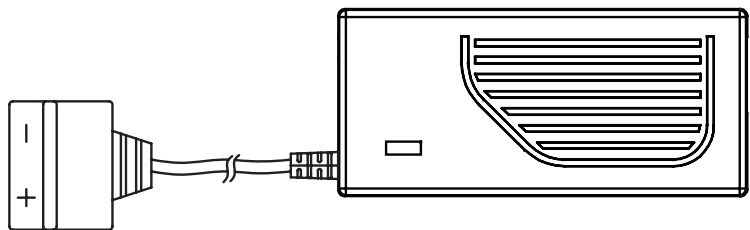

Figure 3

Press and release the Battery Level Check button (Figure 4). The screen displays appropriate Battery level. Please fully charge the Battery when the Battery Press and release displayed is less than two bars.

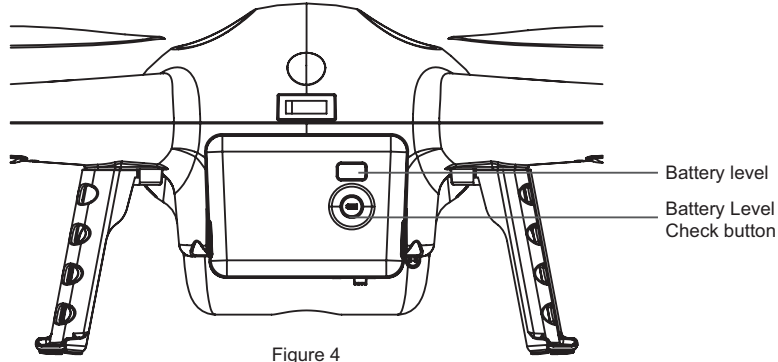

Figure 4

Battery Specifications

Type	Li-Po Battery
Capacity	5300mAh
Charging ambient temperature	0°C-50°C / 32~122°F
Discharging ambient temperature	-20°C-50°C / -4~122°F
Charge / discharge ambient relative humidity	< 80%

Before using the Battery, please carefully read and strictly comply with this manual's instructions. Any problems caused due to failure to follow instructions will be the responsibility of the users.

1.2 Charging the Quadcopter Battery

- 1) Connect the charger to an AC Power source (100-240V, 50 / 60Hz). If necessary, please use a Power adapter.
- 2) While charging, the Battery charger indicator lights up, and turns red.
- 3) When the Battery indicator turns green, it means the Battery is fully charged. Please remove the Battery and disconnect the charger cable from the socket, after the Battery is completely charged.

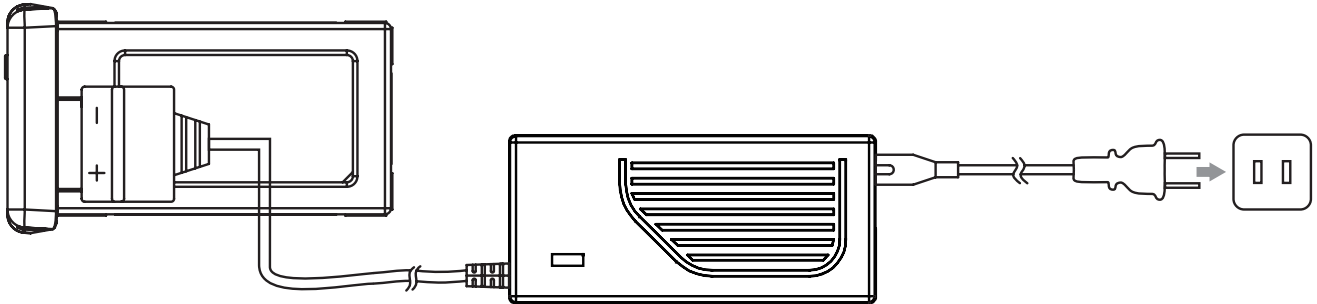

Figure 5

1.3 Installing Quadcopter Battery

Push the Battery in the correct direction (Figure 6) into the Quadcopter's Battery compartment and ensure the Battery is properly installed, before fastening the Battery lock.

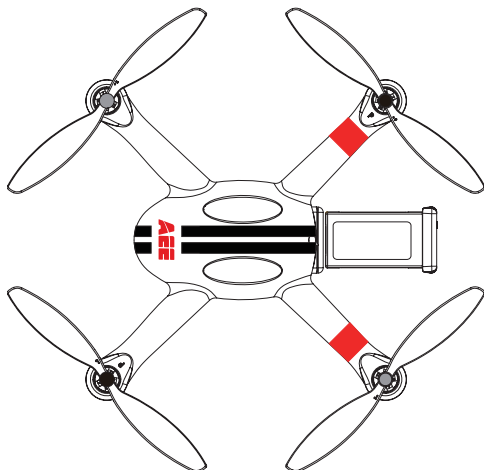

Figure 6

If the Battery lock is not fastened, There may be poor contact with the Battery, which may affect flight safety, or even cause the Quadcopter to fail to take off.

1.4 Caution

- 1) Do not directly pull out the Battery when the Quadcopter is switched on as it may damage the Power supply connector.
- 2) If the Battery is not used for a long time, it is recommended to discharge the Battery to 40%-50% charge level, and store it in a specified Battery box. Discharge/charge the Battery again every three months or so, to maintain Battery life.
- 3) Please replace the Battery after it has been charged at least 300 times or more. Before scrapping batteries and disposing them, please discharge until the Battery is fully depleted.
- 4) Do not continue using the Battery if there is any expansion or damage to the Battery surface, as it may catch fire or explode. Please replace the Battery in such cases.
- 5) Do not charge swollen or damaged Battery.

- 6) Please pay attention while charging batteries to prevent accidents. When charging the Battery, please keep the Battery and charger in a place where there are no flammable or combustible materials on the ground.
- 7) Battery safety is very important. Please refer to the disclaimer notices for more precautions.

2 Prepare the Quadcopter

The Quadcopter includes the flight control system and an airborne Camera that are convenient to use.

2.1 Introduction

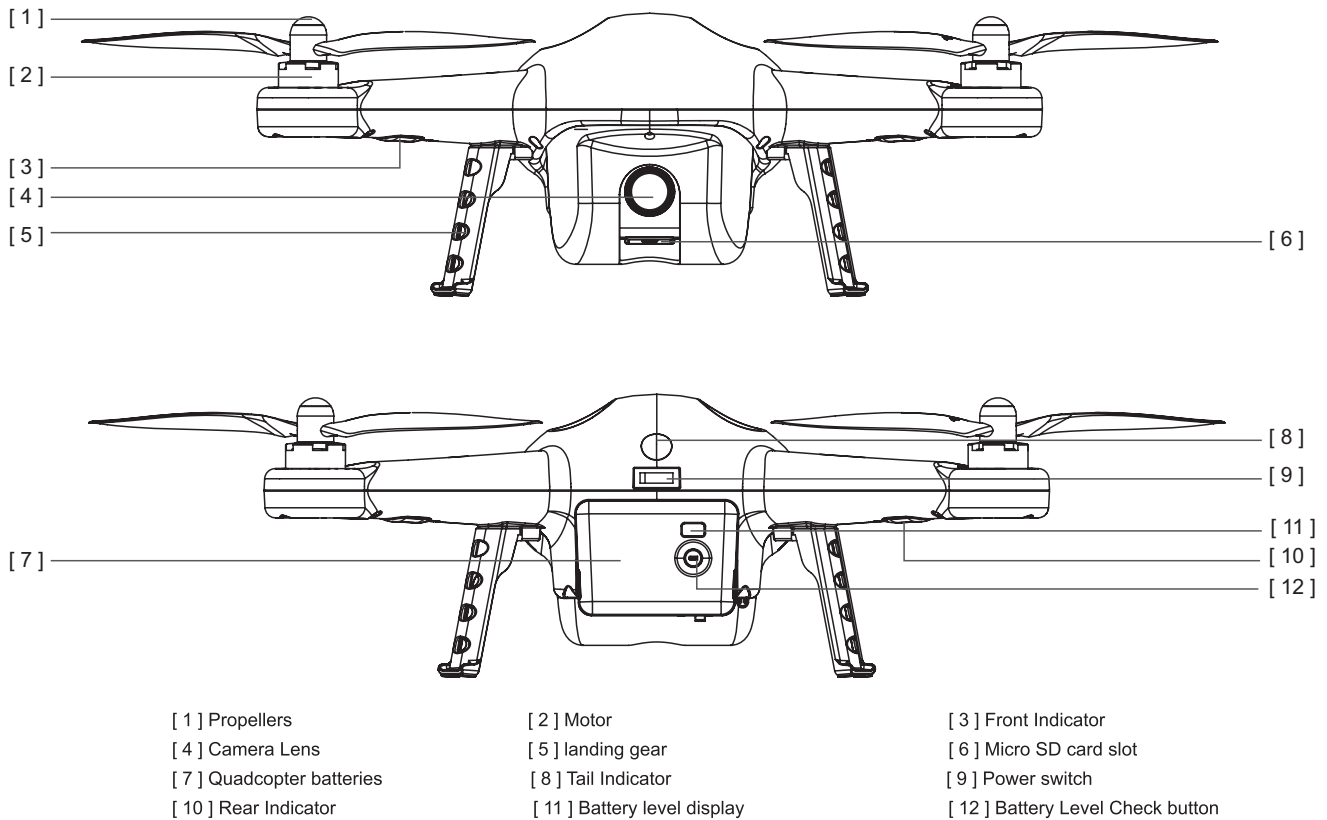

2.2 Flight Control System

AEE AP10 is designed with AEE's flight control system, which is easy to operate and stable. In addition to supporting basic flight maneuvers such as climb, descend, roll and pitch, it also supports failsafe protection, Battery level alarms, smart direction control and other functions.

Flight control system component modules	Function
Master controller	Core module of the flight control system. Connects all the modules and plays the role of centralized control.
GPS & Compass	Used for positioning and navigating the Quadcopter.
Indicator	Indicates current status of flight control system. Used to navigate during night flying.

2.3 Flight Indicator

There are three types LED Flight Indicators, the Front indicator, Rear indicator and Tail indicator. When the Quadcopter switch is turned on, the LED Flight Indicators will be on. The Front indicator is green and the Rear indicator is red. (Hereafter we will use Green / Red Indicator to describe Front / Rear indicators respectively).

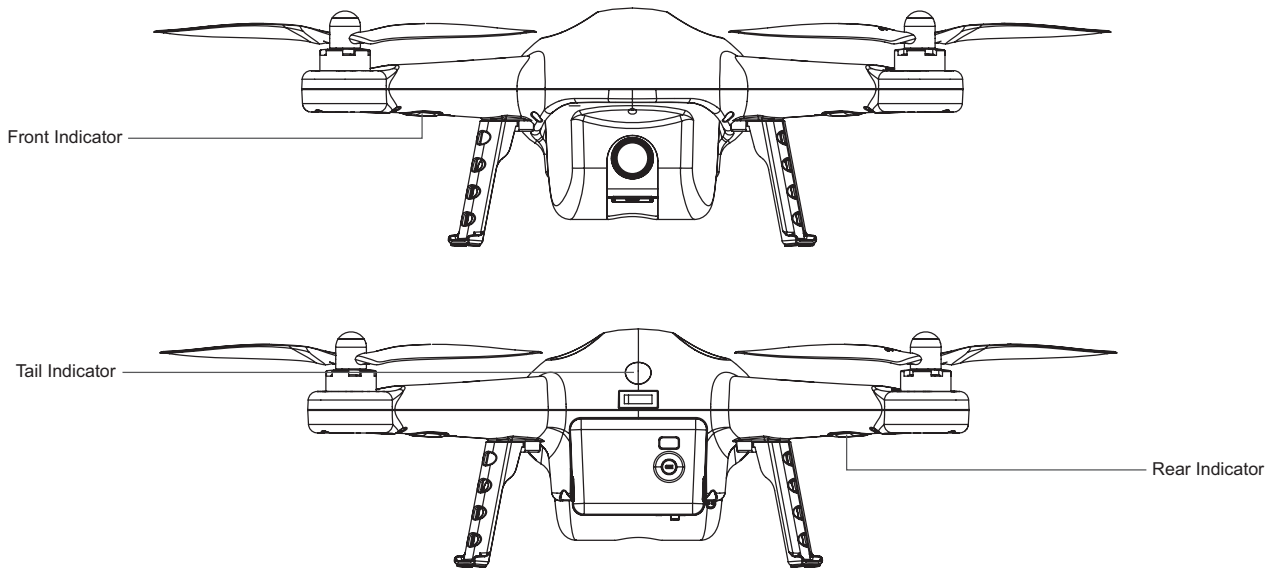

Function	Front Indicator (green)	Rear Indicator (red)	Tail Indicator (red)
Flight Navigation Instructions	Remains ON	Remains ON	
1 st level low Battery alarm	Slow blink (1s ON , 1s OFF)	Slow blink (1s ON , 1s OFF)	
2 nd level low Battery alarm	Fast blink twice at 1 second intervals	Fast blink twice at 1 second intervals	
Barometer abnormal state	Remains ON	Slow blink once at 3 second intervals	
GPS abnormal state	Remains ON	Fast & slow blink twice at 3 second intervals	
Compass abnormal state	Fast blink	Remains ON	
Compass needs calibration	Slow blink	Remains ON	
Accelerometer abnormal state	Fast blink	Fast blink	
Accelerometer needs calibration	Switches ON→OFF→Switches ON	Switches ON→OFF→Switches ON	
Gyro abnormal state	Remains ON	Fast blink	
Gyro needs calibration	Remains ON	Slow blink	
Transmitter Paired with AP10			Fast blink
GPS ready			it will alternate between fast blinking and on

If the barometer/accelerometer/gyroscope/GPS/compass malfunctions, please return the device to dealer for repair.

2.4 Micro SD Card Slot

Before using AEE AP10 to take pictures or record videos, please insert the Micro SD card into the card slot while the Power is OFF. AEE AP10 Micro SD card supports maximum 32GB capacity cards.

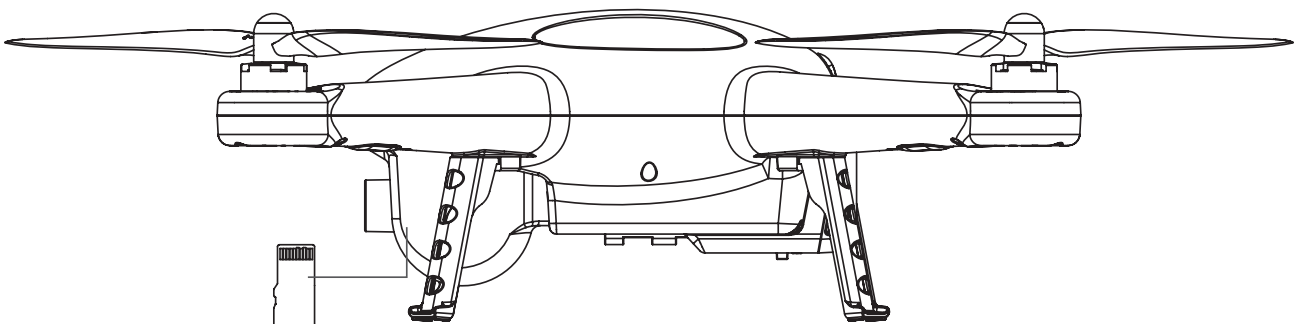

2.5 Onboard Camera

The AEE AP10 Camera's Power is supplied by the Quadcopter's Battery. The Camera Power is on when Power switch is turned on. Users can take photos and record videos by pressing the function key on transmitter, or through AEE AP APP. The Camera supports single shot and continuous shooting mode, and the video resolution is up to 1080P / 30fps (N system) 1080P / 25fps (P system) Full HD video.

Camera Specifications	
Resolution	Maximum 1080P / 30fps (N system) 1080P / 25fps (P system)
Image Resolution	4608x3456
Video file formats	MOV (H.264 compression)
Storage	External Micro SD card, up to 32GB
TV system	P / N system optional

Function Keys

Photo capture function: Press the Airborne Shutter Button on the transmitter to take pictures. Each press snaps one photo.

Video-recording function: AP10 Quadcopter automatic recording is set to ON as a default setting. While video recording, you can press Video Stop Button on the transmitter to stop recording, and then you can press Airborne Video Recording Button to restart video recording.

Copying the Data

When the AP10 Power is switched OFF, remove the Micro SD card from the Micro SD card slot, and connect to a computer with a card reader to easily copy Camera photos and videos. (Quadcopter must be turned OFF while removing the Micro SD card).

Shooting Status Indicator

When the Quadcopter is turned on and the Camera is used for recording and photographing, the Shooting Status Indicator will light up. Users can determine the current Camera status through the Shooting Status Indicator (Camera Status Indicators on the Transmitter are as shown in the below figure. The three LED indicators on the Transmitter are: Transmitter Power Indicator (red), Photo Capture Indicator (green), and Video Recording Indicator (green)

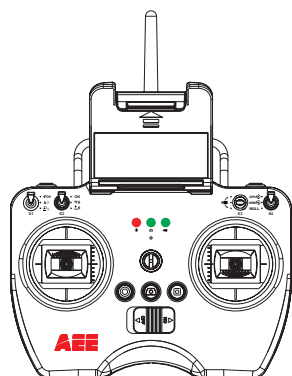

Function Status	Transmitter Indicators		
	Red Light	Green Light	Green Light
	Power supply	Photo capture	Video recording, Code pairing
Start Quadcopter	Remains ON	OFF	On→OFF
	Remains ON	OFF	
	Remains ON	OFF	
Accelerometer calibration	Remains ON	OFF	OFF
Gyro calibration	Remains ON	OFF	
Compass Calibration	Remains ON	OFF	
Start video recording	Remains ON	OFF	Slow blink (1.5 seconds OFF, 0.8 seconds ON)
Stop video recording	Remains ON	OFF	OFF
Photo capture		Flash 0.3 sec	
Photo captured		OFF	
Low Power		OFF	
Code-pairing	Remains ON	OFF	Remains ON
GPS satellite searching	Remains ON	OFF	OFF

- 1) There is alert sound when Transmitter Battery level is low.
- 2) When video recording and photo capture commands are sent from the Transmitter, the Transmitter indicators show the corresponding function status.

3 Prepare Propellers

AEE AP10 uses 10-inch propellers, with black and gray color rotor blade caps. Propellers are consumable items. If necessary, please purchase separately.

3.1 Introduction

Propellers	Gray (1045)	Black (1045R)
Illustration		
Installation Location	⌚ Lock: Tighten propellers onto the motor in this direction.	
Symbol Description	⌚ Unlock: remove the propellers from the motor by untightening in this direction.	

3.2 Installation Method

(As shown below) There are two propellers with gray caps and two with black caps. Attach the propellers with gray caps to the motor shafts without "P" marks and attach the propellers with black caps to the motor shafts with "P" marks. Tighten appropriate propellers as per the locking direction.

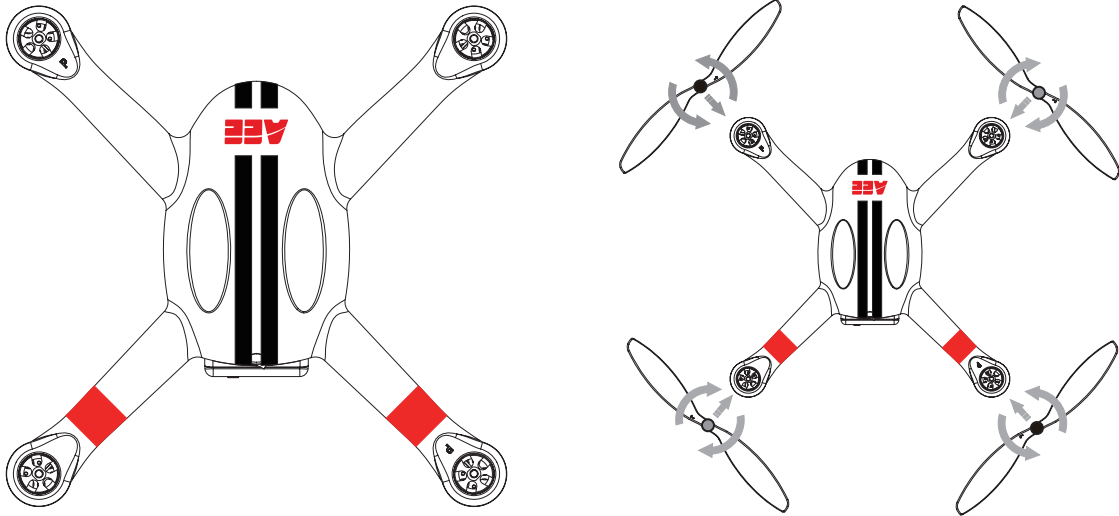

- 1) Propellers are designed for automatic turning, therefore do not tighten excessively during installation. Do not use glue for the screws.
- 2) Please ensure the propellers are installed in the correct position. The Quadcopter cannot fly properly if the propellers are installed incorrectly. Since the propellers are very thin, it is advised to wear gloves when installing, to prevent accidental scratches.

3.3 Removing Propellers

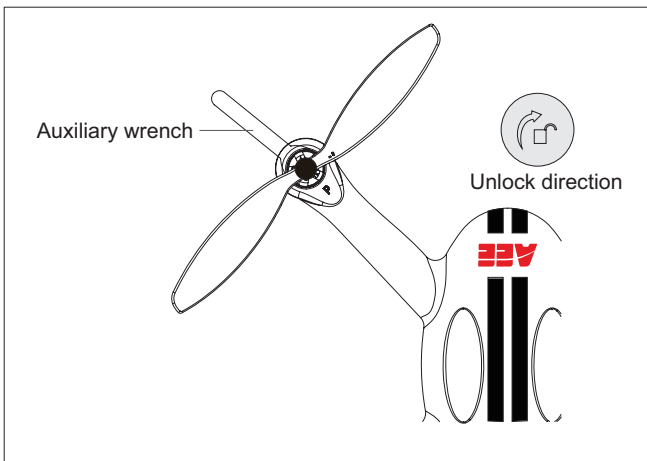

As shown in the illustration, hold the motor with your hand or an auxiliary wrench. Hold and rotate the propellers in the unlocking direction, to remove propellers.

3.4 Precautions

- 1) Before each flight, please check that the propellers are correctly and firmly installed.
- 2) Ensure all propellers are intact before each flight. If the propellers are worn or damaged, please replace before flying.
- 3) Keep your Distance from rotating propellers and the motors to avoid cuts and injury.
- 4) Use only propellers provided by AEE to ensure optimal performance.

4 Preparing the Transmitter

AEE AP10 transmitter is used together with the Quadcopter receiver. The transmitter and receiver have been already adjusted to match Frequency before delivery. The transmitter is set to U.S. mode as the default factory setting mode.

- Control Mode: The transmitter is set to U.S. mode or Japanese mode according to Joystick channel mapping.
- U.S. mode: The transmitter's left Joysticks is the throttle Joystick.
- Japan mode: The transmitter's right Joystick is the throttle Joystick.
- The repeater mount is already installed on the transmitter before delivery. Please install the smart devices mount to place smart devices.
- Oversized smart devices (such as iPad) cannot be installed on the mount, hence it is not recommended.

4.1 Introduction

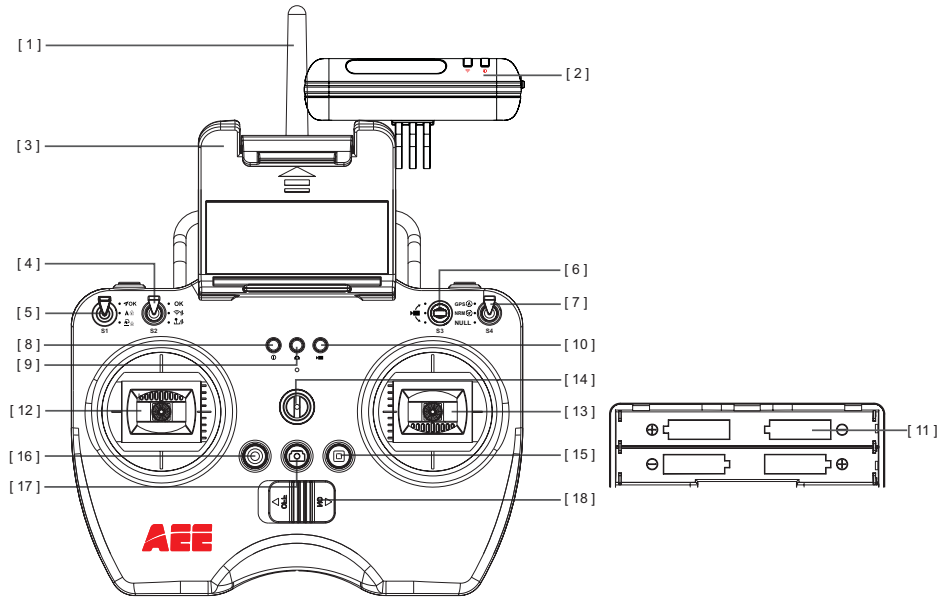

- [1] Antenna
- [2] Repeater
- [3] Smart devices Mount
- [4] 3-position Switch S2
- [5] 3-position Switch S1
- [6] Camera Angle Control S3
- [7] 3-position Switch S4
- [8] Transmitter Power Indicator
- [9] Photo Capture Indicator
- [10] Video Recording Indicator
- [11] Battery Compartment
- [12] Left Joystick ("Up & Down" controls Throttle, "Left & Right" controls Yaw)
- [13] Right Joystick ("Left & Right" controls Roll, "Front & Back" controls Pitch)
- [14] Strap Hole
- [15] Video Stop Button
- [16] Airborne Video Recording Button
- [17] Airborne Shutter Button
- [18] Transmitter Power Switch

Function definition for toggle switch S1~S4 as below:

S1	3 positions, 1. : normal flight 2. heading lock (not open) 3. return point lock (not open)
S2	3 positions, 1. : joystick calibration OK 2. : Quadcopter and wifi range extender pairing 3. : calibrating joystick
S3	3 positions, related control to servo (tilt up) stop (medium) (tilt down)
S4	3 positions, 1. : GPS mode 2. : Normal mode 3. NULL null (reserved)

4.2 Switching on the Transmitter

- 1) Install 4 AA batteries into the Battery compartment as per positive and negative directions
- 2) Ensure the two Joysticks are in the center position. Push switches S1 and S2 to the top position.
- 3) Push the transmitter switch to ON, to switch on the transmitter.
- 4) After switching on the transmitter, the Power indicator remains on and is red.
 - Before each use, make sure the transmitter has sufficient Battery. If the charge is too low, the transmitter will sound a low Power alarm. Please replace the Battery immediately.
 - Please remove batteries, if you do not intend to use the transmitter for a long time.
 - After the batteries are depleted, please remove the batteries and follow the Battery instructions for recycling.

4.3 Antenna Signal Description

Make sure keep the transmitter antenna pointed skyward, and try to ensure there is no obstacle between the transmitter antenna and the receiver antenna, in order to achieve maximum communication range during flight.

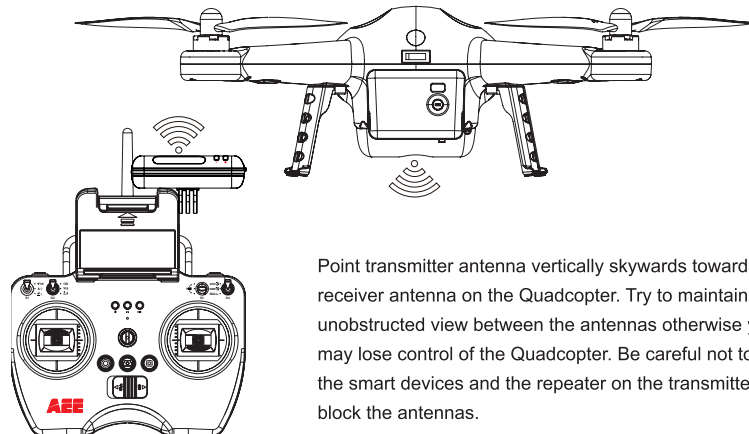



Point transmitter antenna vertically skywards towards the receiver antenna on the Quadcopter. Try to maintain an unobstructed view between the antennas otherwise you may lose control of the Quadcopter. Be careful not to let the smart devices and the repeater on the transmitter block the antennas.

4.4 Transmitter Operating Instructions

Joystick back to center /neutral: Throttle Joystick of the transmitter is set at the center position.

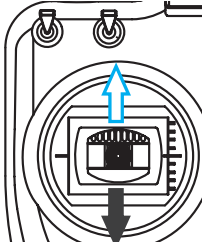
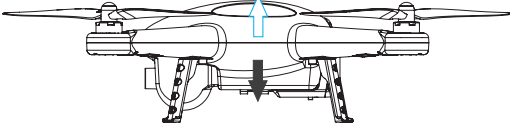
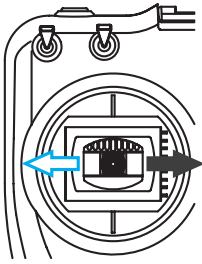
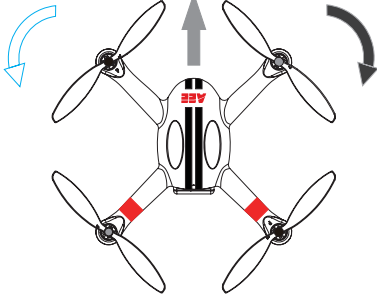
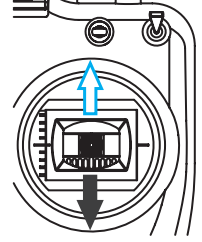
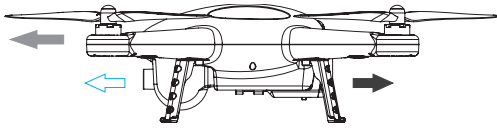
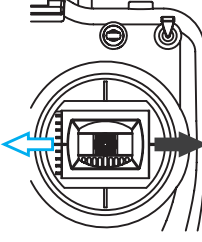
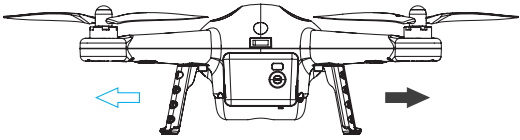
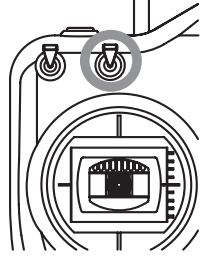
Joystick deviation Distance: The Distance the transmitter Joystick deviates from the Joystick center position.

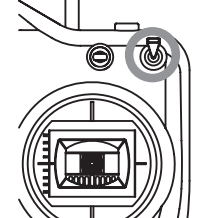
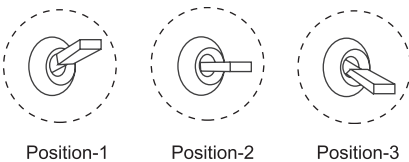
Transmitter(U.S. Mode)	Quadcopter direction	Control Method
		<p>The Left Joystick controls Quadcopter elevation. Push the Joystick up, the Quadcopter rises. Pull the Joystick down and the Quadcopter descends. Keep the Joystick at the center position, and the Quadcopter hovers at that particular height. Push the Left Joystick upwards over the centered position to make Quadcopter take off from the ground. (Please push the Left Joystick slowly to prevent the Quadcopter from suddenly and unexpectedly rising).</p>
		<p>The Left Joystick also controls the Quadcopter rudder. Push the Joystick left and the Quadcopter rotates counterclockwise. Push the Joystick right, and the Quadcopter rotates clockwise. If the Joystick is centered, the Quadcopter flies in the same direction without rotating.</p> <p>The Joystick controls the rotating angular velocity of the Quadcopter. Move the Joystick to increase Quadcopter rotation velocity.</p>
		<p>The Right Joystick controls the Quadcopter's front & back tilt. Push the Joystick up and the Quadcopter will tilt and fly forward. Pull the Joystick down and the Quadcopter will tilt and fly backward. The Quadcopter will keep level and straight if the Joystick is centered. Move the Joystick faster to increase the tilt angle (maximum is 35 degrees), and faster flight velocity.</p>
		<p>The Right Joystick also controls the Quadcopter left & right tilt. Push the Joystick left and the Quadcopter will tilt and fly left. Push the Joystick right and the Quadcopter will tilt and fly right. The Quadcopter will keep level and straight if the Joystick is centered. Move the Joystick faster to increase the tilt angle (maximum is 35 degrees), and faster flight velocity.</p>
		<p>S2 is used to calibrate the left and right joysticks. Toggle S2 to the position 3, and turn on the the transmitter. Then move both joysticks clockwise and counterclockwise twice, ensuring each rotation reaches the maximum degrees. Afterwards, release the joysticks and toggle S2 to the position 1. The video recording indicator (green) will light up for 3 seconds to indicate the completion of the calibration.</p>
		<p>S4 switch is the flight mode toggle switch. Position 1 (GPS) is GPS mode, Position 2 (NRM) is Normal mode, Position 3 (NULL) is Reserved function.</p>

- In GPS mode, when all Joysticks are in the neutral position, the Quadcopter hovers at a fixed-point.
- In Normal mode, when all Joysticks are in the neutral position, the Quadcopter remains level, but may drift in a horizontal direction.

4.5 Frequency Pairing between Transmitter and Receiver

Frequency pairing and the link between Transmitter and Quadcopter's inbuilt receiver have already been set in the factory before any AEE AP10 product is delivered. Therefore, in the beginning you can skip this procedure and switch on to directly use the product. However, if the transmitter or receiver is changed, then re-establishing link and Frequency-pairing is required.

Frequency Pairing Procedures

- 1) Keep the transmitter Powered OFF and turn on the Quadcopter, the Quadcopter Front/Rear indicators as well as Tail indicator will light up. When you hear a "beep" sound, switch on the transmitter, the Video indicator lights up, indicating Frequency-pairing has commenced. When the Tail Indicator (red) continuously blinks fast, the link between the transmitter and receiver is successfully established.
- 2) After the link is established, turn on the transmitter, and then Power on the Quadcopter. The Tail Indicator starts blinking fast, indicating Frequency-pairing is successful.

5 Preparing the Repeater

AEE AP10 repeater is a wireless communication device that works in the 2.4GHz Frequency band, and is used to increase the effective communication Distance between the smart devices and AP10. Communication Distance is affected by the surrounding environment, such as blockages due to trees, signal reflection by buildings, interference by other same Frequency bands, etc., affecting effective communication Distance. Before flight, make sure the repeater works properly, otherwise the connection cannot be established between the smart devices and AP10.

5.1 Introduction

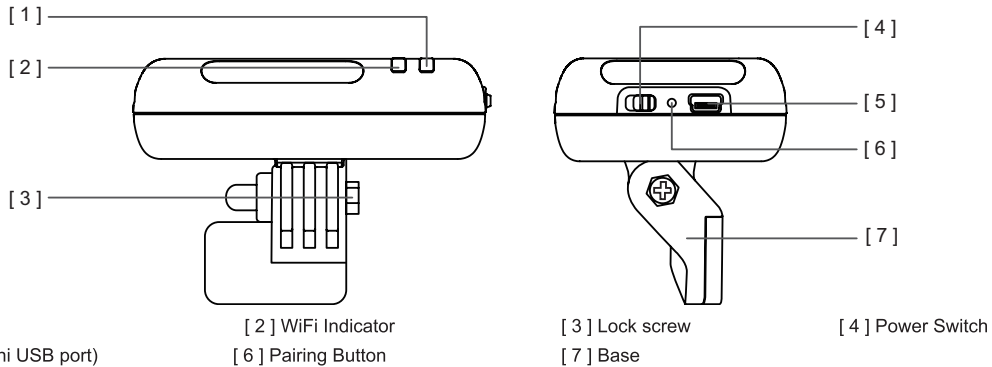

WiFi indicator

Indicates Repeater's WiFi status

WiFi Indicator	Description
Blue light remains ON	Repeater startup completed
Blue light Fast blink (1.5s OFF, 0.3s ON)	Repeater is paired with the onboard Camera.
Blue light Slow blink (3s ON, 0.3s OFF)	Successfully paired repeater with onboard Camera

Power Indicator

Indicates Repeater's Power supply status

Power Indicator	Description
Green light remains ON	Repeater Power supply is normal.
Red light blinks	Repeater is charging, or low Battery, please charge as soon as possible.
Red light remains ON	Charging is completed.

- It is not recommended to turn on the repeater while it is charging.

Pairing Button

When the repeater is on, press and hold the Pairing button for 3 seconds, the repeater will automatically restart for code re-pairing. Press and release the Pairing button to check repeater Power level

Short press Pairing button	Press Pairing button once: If Power Indicator blinks once, indicates that repeater has over 80% charge remaining. If Power Indicator blinks twice, indicates that repeater has over 50% charge remaining. If Power Indicator blinks three times, indicates that repeater is running out of Power.
Long press Pairing button (3 seconds)	Repeater restarts and you can re-pair codes.

Code pairing

The Camera and repeater has undergone pairing before delivery, so it is unnecessary to carry out pairing again. If the Wi-Fi indicator quick blinks blue (1.5 seconds OFF, 0.3 seconds ON), or remains on, please re-pair with following steps:

- 1) Switch on the transmitter Power switch, Quadcopter Power switch and repeater Power switch respectively.

- 2) When WiFi repeater's blue light indicator is on, the repeater is working normally. Toggle S2 switch on the transmitter to the center position then toggle back to "OK".
- 3) Press the repeater pairing button for 3s. The WiFi repeater blue light indicator slow blinks (0.3s on, 3s off). This indicates the repeater has successfully paired with the onboard Camera. If pairing fails, please repeat procedures 2 and 3.

5.2 How to use

Charging the Repeater

Connect the repeater to the mini USB port through the repeater adapter to charge the repeater. It takes about 2 hours to fully charge.

- Before each flight, make sure the repeater has sufficient charge.

Switching on the Repeater

- 1) Toggle repeater Power switch to ON to switch on the repeater.
 - 2) Wait until the WiFi indicator blinks blue, indicating that the repeater works properly.
- 3) While using this process, ensure the repeater's LED side faces you, and try to ensure that visibility between the repeater and Quadcopter is unobstructed, to obtain maximum communication Distance.
- After the flight is completed, in addition to switching off the Quadcopter and transmitter, be sure to turn off the repeater, or else the repeater's Battery will be depleted.

Check Battery status

In AEE AP APP Camera interface, you can display and view AP10 Power information.



You can see AP10 Power information on the upper left corner of the Camera interface.

6 Downloading and Installing AEE AP APP (iOS / Android)

Download and installation methods:

iOS Android users, please search "AEE AP" in the App Store, and download and install the app on your smart devices.



Compatible smart devices

iOS (system version iOS6.1 or above): Applicable for iPhone 4s, iPhone 5, iPhone 5s, iPhone 5c, iPod Touch 4 and iPod Touch 5. iPad 3, iPad 4, iPad mini and iPad Air can also be used. Android (Systemversion 4.0 or above), Applicable for mainstream models can be used.

- AEE will continue to update on future support for more types of smart devices.

7 Connecting the Camera

The procedures to connect the Camera and the smart devices are as follows:

- 1) Turn on the transmitter and repeater.
- 2) Turn on AEE AP10.
- 3) Turn on WiFi on the smart devices. Wait for approximately 30 seconds, and select "AEE_AP****" from the WiFi network list.
 - Please make sure that the smart devices close to the Wi-Fi repeater in order to get better performance of video transmission.

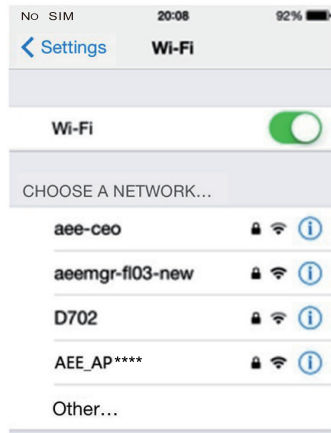

Select this network and enter the password "AEE12345" to join the network.

- 4) Touch the AEE AP APP to launch the app as shown in the below figure.

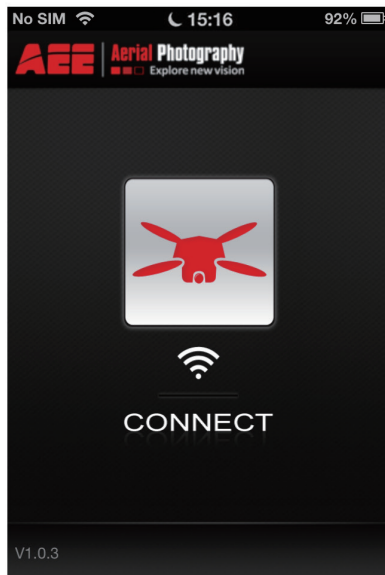

Tap "  " to establish connection between the smart devices and Camera (Andriod users skip this step). After a successful connection the app will navigate to the APP preview interface. If you can see the real-time Camera preview on screen, then the smart devices has successfully connected with the Camera.

- If the connection fails, please check if your network connection is working properly and try to connect again.

Flying the Quadcopter

After installation, please conduct flight training (for example: Flight simulator training or professional training). Please use the Quadcopter an in appropriate flying environment.

Flying Environment Requirements

- 1) Do not use the Quadcopter in inclement weather, such as strong winds (wind speed 4 and above), snow, rain and fog.
- 2) Select an open area with no tall buildings as the flying site. Presence of a large number of a steel buildings in the area will affect the compass.
- 3) While flying the Quadcopter, please stay away from obstacles, people, Power lines, trees, shelters, bodies of water, etc.
- 4) Do not fly in a complex electromagnetic environment (such as near mobile phone base stations or towers) to avoid transmitter interference.
- 5) This product cannot be used in the Antarctic and Arctic Circle.
- 6) Do not fly in restricted or no-fly zones and abide by relevant laws and regulations.

Pre-flight Check:

- 1) Ensure transmitter, Quadcopter, repeater and smart devices are fully charged.
- 2) Ensure propellers are correctly installed.
- 3) Ensure the Micro SD card is properly inserted before using the Camera to capture images and videos.
- 4) After Powering on the Quadcopter, transmitter and other equipment, please ensure they are working properly.
- 5) Check if the motors start properly after the Quadcopter is switched on.
- 6) Check if the AEE AP APP is properly connected to the Camera.

1 Compass Calibration

IMPORTANT: Make sure to calibrate the compass before use or in every new flight location. The compass is very sensitive to electromagnetic interference, which can cause abnormal compass data leading to poor flight performance or even flight failure. Regular calibration is required for optimum performance.

- Do not calibrate the compass in a strong magnetic field.
- Do not carry ferromagnetic material, such as keys, cell phones, etc., while calibrating the compass.

1.1 Calibration Procedures:

Please choose vast and open venues to conduct calibration. Start the transmitter and Quadcopter and ensure the equipment work properly.

Follow the below procedures to calibrate the compass:

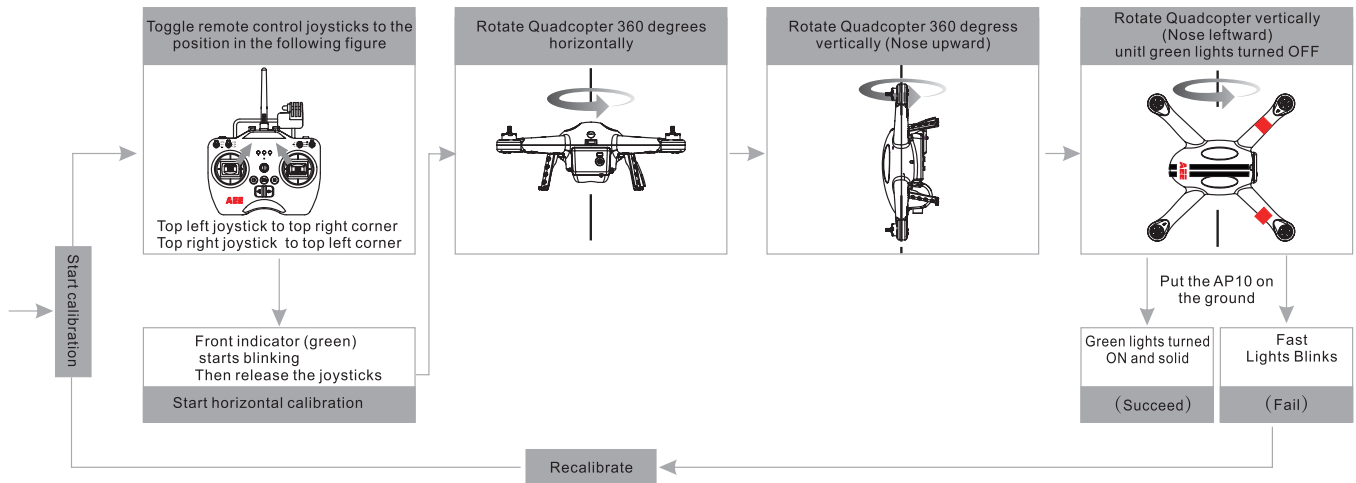

1.2 Situations when recalibration is required

- 1) Compass data anomalies. Front indicator blinks fast.
- 2) Flight venue is far from the place where last compass calibration was conducted.
- 3) There are changes in Quadcopter's physical structure.
- 4) The Quadcopter drifts a lot while flying or it cannot fly straight.

Warning

⚠ Be sure to remove propellers before calibration, to avoid accidental injury.

2 Starting / Stopping the Motor

2.1 Starting the motor

Toggle the Joysticks as shown in the illustration (Combination Joysticks Command [CSC]) to start the motor. After the motors start, please release the Joystick immediately. Camera will start to record video automatically when motor starts.

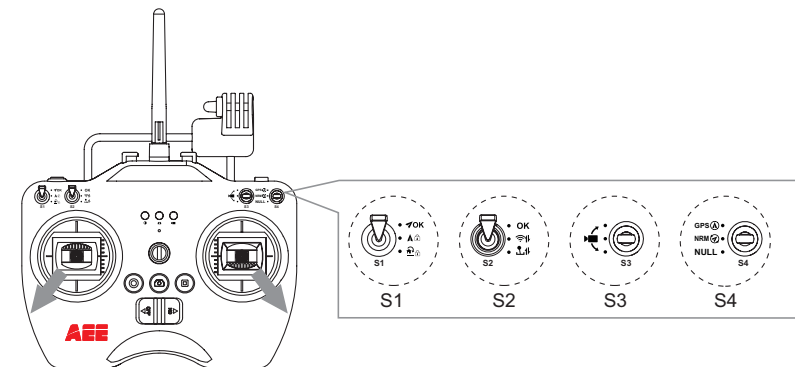

Toggle Left Joystick to left bottom corner
Toggle Right Joystick to right bottom corner

When S4 switch to GPS Mode,

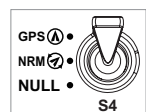

the motor can not be turn on until GPS is ready (Tail indicator will alternate between fast blinking and on).

2.2 Stopping the motor

After the motor starts, there are two ways to stop it. Camera will stop recording automatically after motor stopped.

Method One (Figure 1): After the Quadcopter lands, toggle the throttle Joystick to the lowest position and then perform CSC, the motors will immediately stop. Release the Joysticks after the motors stop.

Method 2 (Figure 2): After the Quadcopter lands, toggle the throttle Joysticks to the lowest position and hold for 3 seconds to stop the motor.

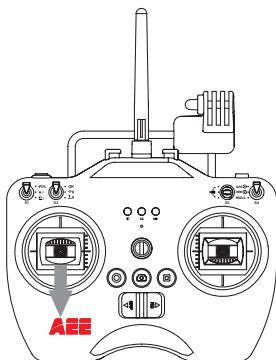

Figure 1

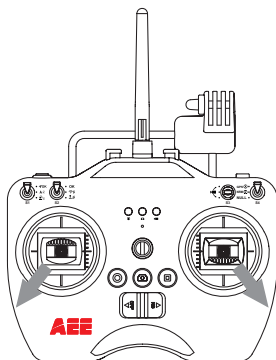

Figure 2

- Do not stop the motor during flight, or else the Quadcopter may crash.

When performing CSC, toggle the Joystick quickly and accurately. Release the Joysticks after the motors start or stop.

3 Basic Flight

3.1 Basic Flight Procedures

- 1) Place AP10 on a flat and open ground, and ensure Tail indicator faces toward you.
 - 2) Turn ON the transmitter, repeater and Quadcopter.
 - 3) Run AEE AP APP, connect the smart devices and AP10, and navigate to the Camera preview screen.
 - 4) Wait until the tail indicator blinks slowly and the Quadcopter enters a safe flying state. Perform CSC to start the motor.
 - 5) Push the throttle joystick up slowly to smoothly take-off the Quadcopter. Please refer to transmitter control instructions for detailed control procedures.
 - 6) Use the AEE AP APP to take photos and videos, and enjoy the flight. For details, please refer to Using AEE AP APP.
 - 7) When landing, slowly pull down the throttle Joystick to make the Quadcopter descend slowly to the ground.
 - 8) After landing, pull the throttle Joystick to the lowest position and hold for 3 seconds or until the motors stop.
 - 9) After motors stop, turn off the Quadcopter, repeater, and transmitter one after the other.
- During flight if all 4 arms indicators slow blink, then the Quadcopter has entered a low Battery state. Please refer to the Battery warning functions for details.

3.2 Aerial Photography Tips and Tricks

- 1) Perform pre-flight checks.
- 2) Try to take pictures or videos during safe flight status.
- 3) Try to capture photos and record videos in sunny weather with little wind.
- 4) Set Camera settings as per shooting requirements, such as video resolution, picture size, etc.
- 5) Carry out a trial flight before actual flight to help plan the route and frame your photos and videos.
- 6) During flight push the throttle Joystick as slowly as possible, to ensure the Quadcopter flies smoothly.

4 Failsafe Protections

With the Failsafe mode, if the Quadcopter loses the signal from the transmitter (i.e., you lose control), the Automatic Flight Control system will control the Quadcopter, return it to the home point and land it safely. This reduces chances of the Quadcopter getting lost or crashing in case transmitter signal is lost.

- Home Point: Indicates the Quadcopter's position when the Quadcopter's GPS successfully scans and connects to the satellite.

4.1 Scenarios when Quadcopter enters Failsafe mode

- 1) When transmitter is turned off.
- 2) The flight Distance is beyond the effective range of the transmitter signal.
- 3) There are obstructions between the transmitter and the Quadcopter.
- 4) There is interference with the transmitter signal.

4.2 Failsafe and Return Procedure

In case you lose control of the Quadcopter during flight, the Quadcopter will automatically follow the below operating procedures:

- 1) The Quadcopter automatically slows down and hovers in one location.
- 2) If the Quadcopter regains signal from the transmitter within 2 seconds, flight control returns to Normal mode, and the Quadcopter will not enter Failsafe mode and will not automatically fly back to the Home Point.
- 3) If the Quadcopter does not regain signal from the transmitter within 2 seconds, the Quadcopter enters Failsafe mode, and initiates automatic flight control to fly back to the Home Point. The Quadcopter will now continue to hover for 15 seconds and evaluate vertical Distance to the Home Point. If the Distance is more than 15 meters, the Quadcopter will commence to fly back to the Home Point. If the Distance is less than 15 meters, the Quadcopter will fly up vertically 15 meters higher than the Home Point, and then commence to return. When the Quadcopter reaches the Home Point it will hover for 5 seconds and then automatically land.

- To ensure the Quadcopter successfully flies back to the Home Point when it is in Failsafe mode, please take-off only after the Quadcopter's GPS successfully connects to the satellite.
- The Quadcopter cannot automatically avoid obstacles in its path when it is flying in Failsafe mode.

4.3 How to regain control on the Transmitter

When the Quadcopter is out of control, toggle the S4 switch on the transmitter several times to switch flight mode. When the signal is restored, the transmitter will regain control, and you can continue to use the transmitter to operate the Quadcopter.

5 Battery Level Alarm Function

When Quadcopter Battery Power is low, it has insufficient Power and you must land it as soon as possible, or else it may lose Power completely and crash, damaging the Quadcopter or create a dangerous situation. In order to prevent danger caused by low Battery, the Quadcopter has a two-level Battery alarm function. Level 1 is a Low Power alarm and Level 2 is a Severe Low Power alarm that is indicated by the flight indicator lights.

Low Power alarm	Flight indicator light status	Low Power risk prompt
Level 1 alarm	2 Front Indicator and 2 Rear Indicator Slow Blink (blinks on and off in 1s intervals)	In level 1 alarm condition, Quadcopter flies normally for few minutes and then initiates Level 2 alarm. Be cautious while flying, keep the Quadcopter within sight and do not to fly too high or too far.
Level 2 alarm	2 Front Indicator 2 Rear Indicator Fast Blink (blinks twice within 1s)	In level 2 alarm condition, Quadcopter flies normally for few minutes and then initiates Failsafe mode and commences to automatically land. Under such a situation, please return and land the Quadcopter as safely as possible, and do not push the throttle hard or make big movements during flight.

During low-Power automatic landing, you can regain control of the Quadcopter by switching the flight mode. However, do not do so repeatedly, as it may:

- 1) Reduce battery service life due to over discharge.
- 2) Quadcopter may crash due to insufficient Power.

Using AEE AP APP

The AEE AP APP is primarily used to control the Quadcopter Camera. It can be used to configure video and Camera parameters, control the Camera angle and capture images and videos. It can also display Quadcopter status parameters.

1 Download and Install AEE AP APP

To use the AEE AP APP, please download the app and install it on your smart device.

Please ensure your smart devices is connected to the internet, enter the "App Store", type "AEE AP " in the search field and search. You will find the application icon shown in the search results and follow the prompts to complete installation.



2 Connect to AP10 System Network

Before you start using the APP, you need to connect to the AP10 system network. The specific procedures are as follows:

Navigate to smart devices "Settings" - "Wi-Fi" page. Locate the "AEE_AP****" network in the "Select Network" list.

Select this network, enter the password (default password is "AEE12345"), and connect.

- Please make sure that cell phone close to the Wi-Fi repeater in order to get better performance of video transmission

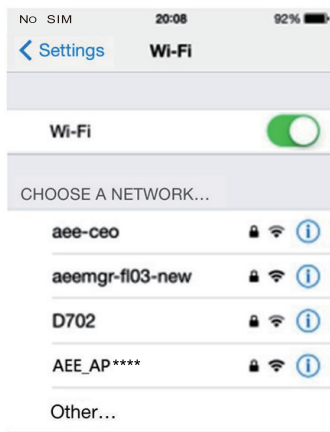

3 Starting AEE AP APP

Touch the AEE AP APP icon to launch it. The app will display the below interface on the smart devices:

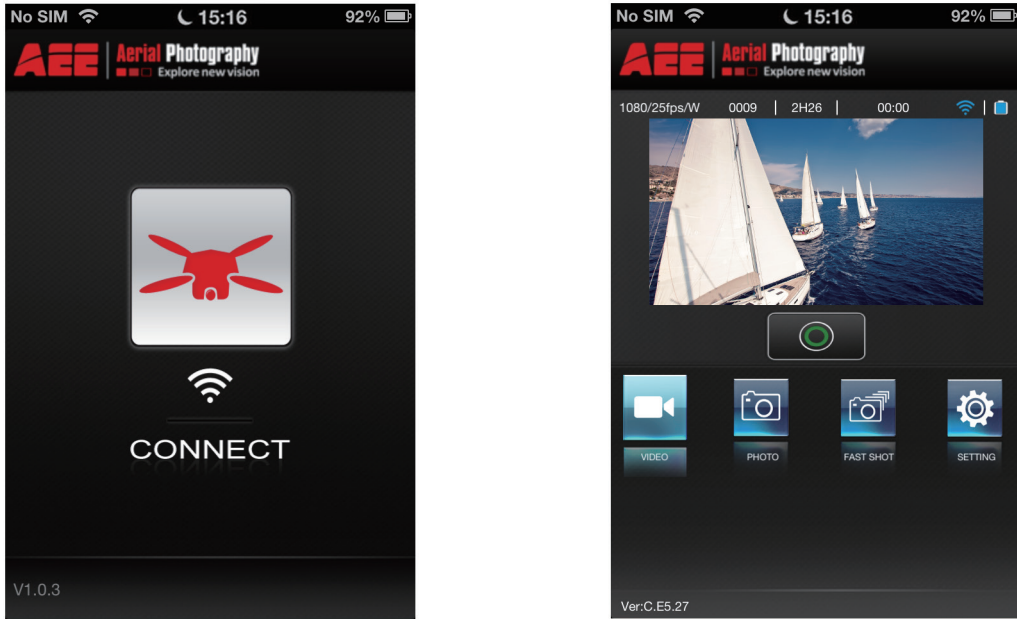

- Touch "  " to establish connection between the smart devices and Camera (Andriod users skip this step). After connection is successful, the app will display the APP preview interface.
- If connection fails, please check if your network connection is working properly, and then try to connect again.
- If you receive a phone call on the smart devices while flying the Quadcopter, the smart devices will display the Call screen. Do not answer phone calls while the Quadcopter is flying as it may distract you and affect flight safety.

4 AEE AP APP Main Interface

After successfully connecting to AEE AP APP, you can see the APP preview screen as shown in the figure below.

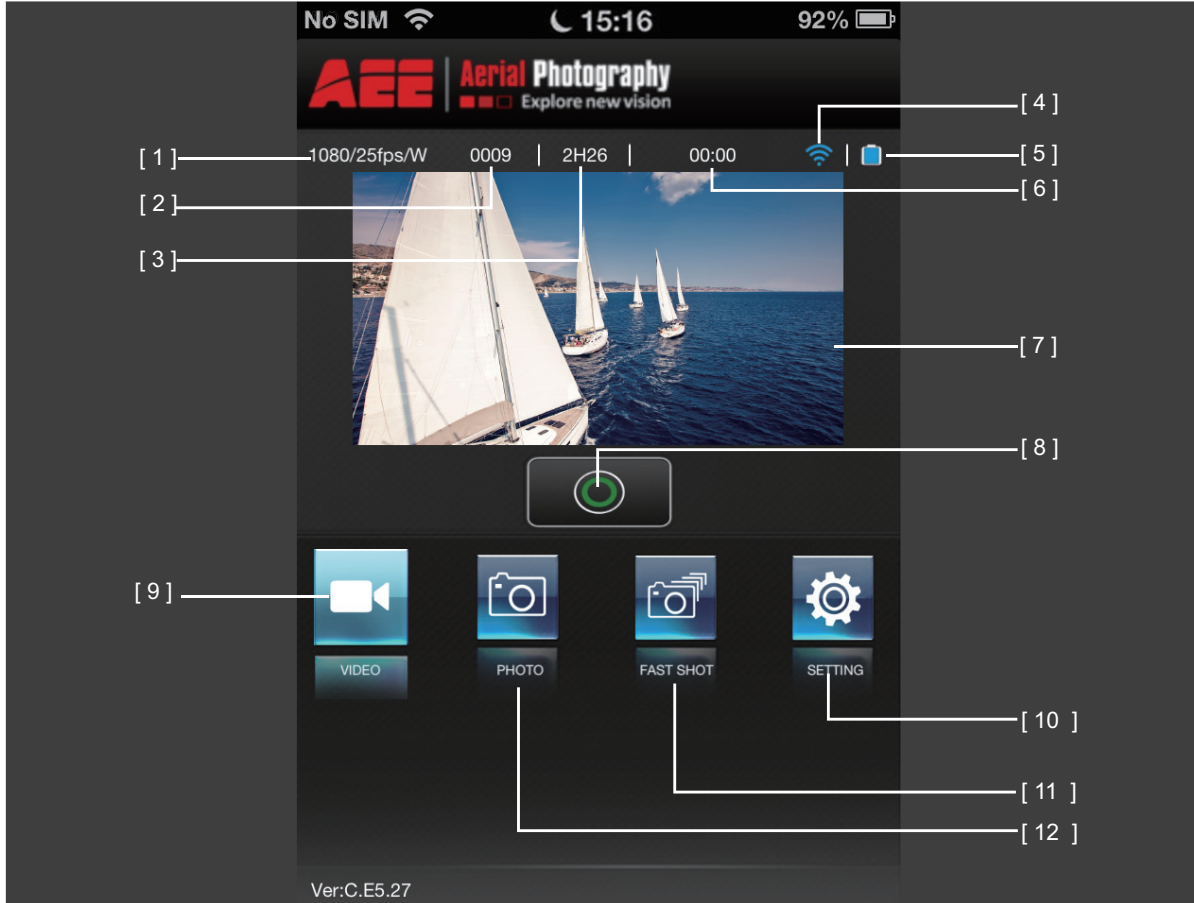

No.	Function	Description
[1]	Video Resolution	Maximum video resolution is 1080P / 30fps (N system), 1080P / 25fps (P system).
[2]	Number of files stored in Micro SD card	0007 indicates there are 7 files stored in the Micro SD card.
[3]	Camera available shooting duration	0H55 indicates under current Camera settings, the Micro SD card can store a further 0 hours 55 minutes of video
[4]	WiFi signal strength	The Wi Fi signal strength between AP10 and Wi-Fi repeater.
[5]	AP10 Power level	AP10 Battery level.
[6]	Recording time	When the Camera starts recording video, recording time will be displayed.
[7]	Video Preview window	Watch videos recorded in real time
[8]	Operation button	Operation button has different functions in different shooting modes: Recording mode: Press "Operation button" to start video recording; Press "Operation button" again to stop recording. Camera mode: Press "Operation button" once to capture photo. Snapshot mode: Press "Operation button" once to capture photos.
[9]	Video recording mode	In this mode, the airborne Camera can record videos.
[10]	Settings button	View and configure airborne Camera settings.
[11]	Snapshot mode	"Snapshot mode" toggle button.
[12]	Camera mode	"Camera mode" toggle button.

The preview screen is always shown in portrait mode. Even when the smart devices is turned sideways, the APP's interface remains in portrait mode. Touch the "preview" area to change the APP interface to video preview interface screen, which supports both portrait and landscape modes.

5 Video Interface

Touch the "preview" area to enter the video interface as shown in the picture below. When the smart devices is horizontal, the APP interface will also change to landscape mode as shown in the picture.



The main interface and video interface function buttons are essentially the same, except there are two additional function buttons for zoom in the video interface.

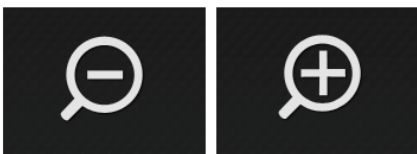

Other function buttons have same functions as in the main interface.

6 Settings Interface

When the AEE AP APP is successfully connected to the smart devices, we can change Camera and video parameter settings in the setting menu, to meet different photo and video requirements.



In the Settings interface, you can view / modify airborne Camera parameters.

Menu	Settings	Description	Parameters
WiFi	Wireless Network Name	Display the "Wireless Network Name" that phone is connecting to	
Recording Settings	Resolution	Set the video resolution.	1920x1080P 025f 16:09 _____ 1280x0960P 048f 04:03 _____ 1280x0960P 025f 04:03 _____ 1280x0720P 050f 16:09 _____ 1280x0720P 025f 16:09 _____ 0848x0480P 100f 16:09 _____ 0848x0480P 050f 16:09 _____
	Angle	Set shooting angle for the lens.	Angles incl.: Wide / Medium / narrow / small
	Bit Rate	Set video encoding bit rate.	Normal / High
Camera Settings	Resolution	Set Camera pixel ratio.	8.0M (3264x2448 4:3) _____ 12.0M (4096x3072 4:3) _____ 16.0M (4608x3456 4:3) _____
	Snapshots per second	Set the number of frames per second for snapshots	3 / 6 / 10 frames
Parameter settings	Looped video recording	When memory card storage space is insufficient, choose this option to overwrite memory card contents.	Yes/No
	TV output format	Select appropriate TV output format to record videos. Different output formats match different recording frame rates.	PAL/NTSC
	Date / Time	Synchronize Camera's date and time with smart devices	
	Format memory card	Format Camera's Micro SD card.	Used to delete all memory card contents (Please maintain data backup before formatting the memory card).
	Version	Displays Camera's software version number.	
	Model	Displays Camera model.	
Others	About	Display APP version information	

Users can configure airborne Camera settings as per their own requirements.

Appendix

1 Description of Common Indicators

Normal State	
Front and Rear Indicators are ON; Tail Indicator Fast Blinks	Enter normal mode
Front and Rear indicators Remains ON, Tail Indicator Slow Blinks	Enter GPS mode
Warnings and Abnormal State	
Front and Rear Indicators Slow Blinks	Low Power alarm (first-level low Power alarm)
Front and Rear Indicators Fast Blink	Severe low Power alarm (second-level low Power alarm)

Above indicator descriptions refer to common LED indicator states. For specific details, please refer to "Prepare the Quadcopter" in section 2.3 LED indicators.

2 Specifications

Quadcopter	
Battery	5300mAh LiPo
Weight	1.4kg / 3.09lbs
Hover Accuracy	Horizontal: 2m / 6.56ft , vertical: 1m / 3.28ft
Maximum tilt angle	35°
Maximum climb / descent speed	Climb: 8m/ s-26.25ft/s; Descend: 5m / s -16.4ft/s
Maximum flight speed	20m/s - 65.62ft/s (Not recommended)
Wheelbase	450mm / 1.48ft
Flight Time	25min
Camera	
Ambient operating temperature	0-50°C / 32~122°F
Sensor Size	1/2.3
Effective Pixels	16 Megapixels (MP)
Resolution	4608x3456
HD video recording	Maximum 1080P / 30fps (N system), 1080P / 25fps (P system)
Transmitter	
Data / Video transfer distance	1000m(3280ft) / 500m (1640ft)
Battery duration	8h
Operating current / voltage	150mA/6V
Battery	4 AA Batteries
Repeater	
Operating Frequency	2.4GHz
Communication Distance (open outdoors)	300m / 984ft
Transmitting Power	<=17dBm
Power Consumption	1.5W

3. Common Troubleshooting

3.1 Solution for transmitter Joysticks center (neutral) position errors

When there is a big difference in transmitter Joysticks neutral position, the motors cannot start when performing CSC. Errors in transmitter Joysticks neutral position usually occurs in two cases:

1. When Quadcopter is ON and the Joysticks (except throttle) is not in neutral position - Solution: Please move all transmitter Joysticks to neutral position, and re-start the Quadcopter, to re-record the neutral position. If the problem persists, it may be caused due to case 2.
2. Transmitter Joysticks is over tuned, leading to a large shift in position, i.e., there is a large asymmetry in transmitter Joysticks position - Solution: Recalibrate the transmitter.

a) S2 is used to calibrate the left and right joysticks. Toggle S2 to the position 3  , and turn on the the transmitter. Then move both joysticks clockwise and

counterclockwise twice, ensuring each rotation reaches the maximum degrees. Afterwards, release the joysticks and toggle S2 to the position 1  . The video recording indicator (green) will light up for 3 seconds to indicate the completion of the calibration.

b) Re-start the Quadcopter, and ensure the Quadcopter starts properly.

If the problem cannot be solved by the above methods, please send the transmitter back to our factory for repair.

3.2 Quadcopter is invisible and WiFi is disconnected

Turn off the transmitter and let the Quadcopter automatically return. Make sure there are no obstructions on the Quadcopter's return path, and ensure you are familiar with the procedures on how to regain control of the Quadcopter.

3.3 WiFi could not be re-connected

This is probably because after the smart devices disconnects from AP10's WiFi connection, the smart devices automatically connects to other WiFi networks. Please check to see if your smart devices is connected to the AP10 WiFi network.

3.4. Precautions when multiple smart devices use the APP at the same time

During flight if the APP is used on one smart devices and then shifted to another smart devices, please make sure you completely log out from the APP in the original smart devices, so that the APP can function normally on the other smart devices.

3.5 How can you smoothly land the Quadcopter?

Before performing CSC, pull down the Left Joystick to less than 5% of the Joystick level, and then execute CSC. This way you can land the Quadcopter smoothly.

Limited Warranty

AEE products are guaranteed against manufacturing defects, AEE's sole obligation in the event of such defects during this period is to repair or replace the defective part or product with a comparable part or product at AEE's sole discretion. Except for such repair or replacement, the sale, processing or other handling of this product is without warranty, condition or other liability even though the defect or loss is caused by negligence or other fault. Damage resulting from use, accident, or normal wear and tear is not covered by this or any warranty. AEE assumes no liability for any accident, injury, death, loss, or other claim related to or resulting from the use of this product. In no event shall AEE be liable for incidental or consequential damages relating to or resulting from the use of this product or any of its parts. Because of possible user resealing error, this product is not warranted against waterproof housing leakage or any resulting damage. Returns or replacements of parts and/or products may be subject to shipping, handling, replacement and/or restocking fees.

If you are experiencing a problem with an AEE purchase, please contact our Customer Support Team by visiting our website www.aee.com.

For product warranty period and conditions, please refer to www.aee.com for details.

Tip: If you bought from a AEE authorized dealer, we would recommend that you contact them firstly regards to technical support issues



This manual is subject to change without notice.
You can check the official AEE website for the latest updated version.

